



DATA INQUIRY SHEET

8533 "D" SERIES

SEA MACH AIR CONDITIONER

Capacitor (Nominal BTUH)	Cooling - Output BTU 13,500 Heating - Output BTU (1) 5,600
Electrical Rating	115 VAC, 60 HZ, 1 Phase
Cooling Full Load AMP's at A.R.I. Standard Condition (80 Degrees F. DB 67 Degrees F. WB Indoor, 95 Degrees F. DB Outdoor)	Compressor 11.4 Fan Motor Low 2.7 High 3.4 Total 14.1 14.8
Feature Equipment Amps	Heating (1) 16
Running Watts: (cooling) A.R.I. Standard Condition (80 Degrees F. DB 67 Degrees F. WB Indoor, 95 Degrees F. DB Outdoor)	1617
Running Watts: (cooling) A.R.I. Maximum Condition (95 Degrees F. DB 71 Degrees F. WB Indoor, 115 Degrees F. DB Outdoor)	1950
Running Watts: (heating) (1)	1800
Compressor Locked Rotor Amps	67
Thermostat Temperature Range	Cooling - 61 Degrees F. (±5) Heating (1) - 85 Degrees F. (±)
Metering Device	Capillary Tube
Refrigerant Charge	17.50 oz.
Evaporator Air Delivery (CFM)	320 CFM - High Speed
Generator Size	See "Generator" Below
Unit Weight (pounds) Heat/Cool	99 lbs. (2)
Use time delay fuse or circuit breaker (U.L. H.A.C.R. Type C.S.A.) Rated at 20 amps. Supply wires 12 AWG Min. (Copper)	

- (1) When equipped with Elect-A-Heat feature.
- (2) Ceiling assemblies may add an additional 3.5 to 12.5 lbs. depending on the model number.

CEILING ASSEMBLY: Any 8330 or 9330 Series

GENERATORS:

It is not the policy of RV Products to size generators for application in Recreation Vehicles or related structures. However, when sizing generators, the total electrical power consumption in Watts must be determined and taken into consideration, such as:

- A. Maximum running watts of the air conditioner at A.R.I. maximum operating conditions (See Specifications).
- B. Power consumption of electronic ovens, toasters, coffeemakers, television sets, refrigerators, lights, etc.
- C. Generators do lose capacity under the following conditions: (1) Altitude increases above sea level, (2) Temperature increases above certain outdoor design temperatures and (3) Lack of maintenance.

RV Products
A Division of Airxcel, Inc.
P.O. Box 4020
Wichita, KS 67204

ROOF TOP UNIT DIMENSIONS

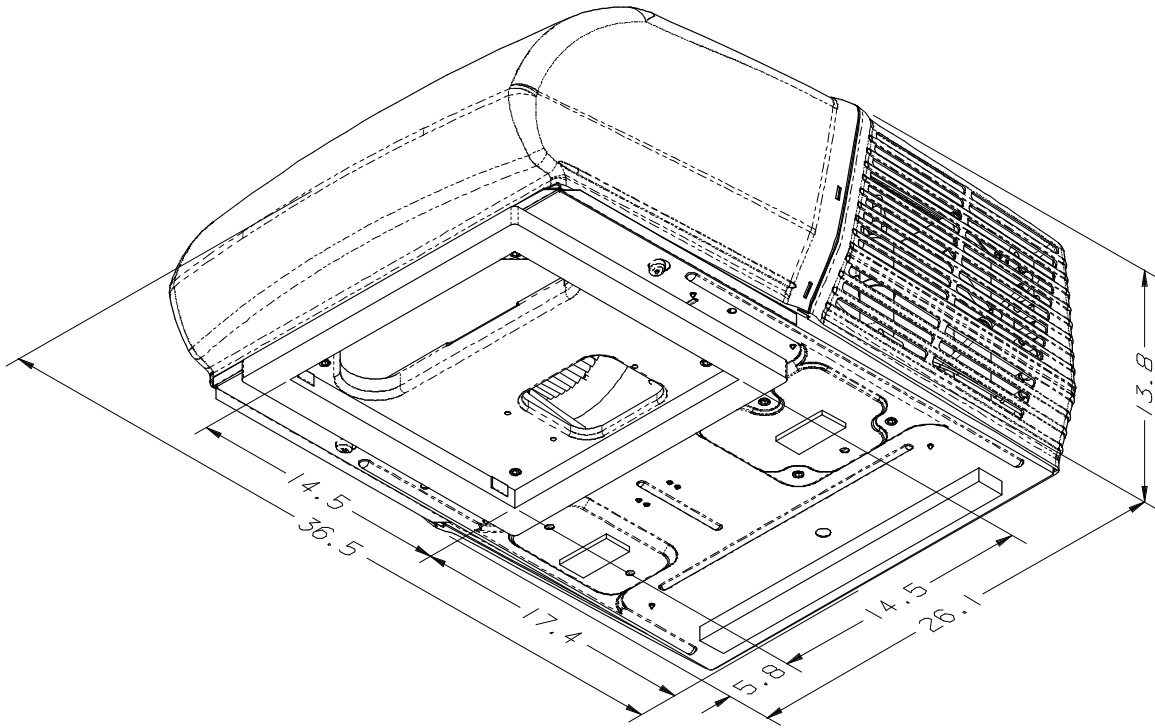

QUICK REFERENCE CHART

DIMENSIONS		
Exterior Shroud	Height	13.59"
	Width	26 1/8"
	Length	36"
Interior Shroud	Depth	2.1"
	Width	19.9"
	Length	20.1"

CEILING SHROUD DIMENSIONS

