



RV Products  
A Division of Airxcel, Inc.  
P.O. Box 4020  
Wichita, KS 67204

**Web:** [www.rvcomfort@airxcel.com](http://www.rvcomfort@airxcel.com)  
**Support:** [www.rvsupport@airxcel.com](http://www.rvsupport@airxcel.com)  
**Sales:** [www.rvsales@airxcel.com](http://www.rvsales@airxcel.com)

INSTALLATION AND OPERATING INSTRUCTIONS  
FOR 6536- 335\*  
2 STAGE HEAT PUMP WALL THERMOSTAT

\* Last digit represents  
specific model number



## C. ATTACHING THE WALL THERMOSTAT

1. Separate the thermostat cover from the base by gently pulling at the left and right. See Figure 2.
2. Connect plugs to motorcoach wiring harness.
3. Attach the new thermostat base to the wall at the desired mounting location.
4. Reattach thermostat cover to base.

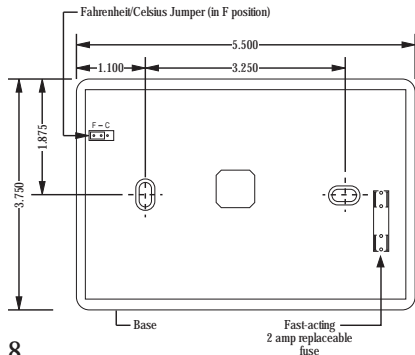

8

6536-335\* Thermostat

## OPERATION

The display indicates room temperature and the word ROOM is shown on the LCD until the temperature selector is pressed; at which time the display temporarily indicates the setpoint temperature and the word SET is shown on the LCD. Each time the UP arrow is pressed, the setpoint will increase. Each time the DOWN arrow is pressed, the setpoint will decrease. Once the temperature selector button is no longer pressed for a few seconds, the room temperature will again be displayed, and the word ROOM will be displayed on the LCD.

In electric heat mode, if the heat pump is unable to satisfy the thermostat, the heat pump goes into lockout. See heat pump & back-up heat example on Page 4 for conditions of heat pump lockout. DIFF will display on the thermostat LCD indicating backup heating is required to satisfy the thermostat.

In gas heat mode, the gas furnace will provide the only source of heat and the heat pump is locked out.

TEMPERATURE		
MODE	RANGE	
	F	C
Cooling (set)	98-33 F	37-1 C
Heating (set)	98-33 F	37-1 C
Display (room)	99-32 F	38-0 C

### NOTE 1

The temperature is displayed in degrees Fahrenheit as a factory set default (See Figure 2). To display in degrees Celsius, move the jumper marked "F" and "C" to bridge between middle pin and position "C", then cycle 12 volt power off then back on again.

Refer to operation table (pages 2&3) for a more detailed listing of operation sequence.

1

## A. THERMOSTAT LOCATION

This thermostat is a sensitive instrument. For accurate temperature control and comfort, the following considerations should be taken into account:

1. Locate the thermostat on an inside wall about five feet above the floor. Pick a dry area where air circulation is good.
2. Do not install the thermostat where there are unusual heating conditions; such as direct sunlight, heat producing appliances (television, radio, wall lamp, etc.) or a furnace or air conditioner supply register.

## B. WIRING THE WALL THERMOSTAT

OEM must supply these mating parts to connect these thermostats per Figure 1. The plugs must be connected to motorcoach wiring harness before the base is secured to the wall.

	Mode Switch	Fan Mode Switch	Fan Speed Switch	Calling	Operation
10	Cool	On	Hi	No	ID fan high continuous
11	Cool	On	Hi	Stage 1 1 Above Set	ID fan high continuous, compressor #1 and OD blower low cycle as needed
12	Cool	On	Hi	Stage 2 2 Above Set	ID fan high continuous, compressors #1 & #2 and OD blower high cycle as needed
13	Off	Auto	Lo or Hi	N/A	No functions occur in this mode
14	Off	On	Lo	N/A	ID fan low continuous
15	Off	On	Hi	N/A	ID fan high continuous
16	Gas Heat	Auto or On	Lo or Hi	No	No functions occur in this mode
17	Gas Heat	Auto or On	Lo or Hi	Stage 1	Heater will be energized to run
18	Gas Heat	Auto or On	Lo or Hi	Stage 2	There is no provision for backup heat when operating in the gas heat mode
19	Elec Heat	Auto or On	Lo or Hi	No	No functions occur in this mode
20	Elec Heat	Auto or On	Lo or Hi	Stage 1	Heat Pump will run ID fan high, both compressors, OD fan high and both reversing valves
21	Elec Heat	Auto or On	Lo or Hi	Stage 2 *See Note 2* on Page 4.	Backup heater will be energized to run.



# OPERATION CHART

The chart below shows the system functions with the 6536-335\* thermostat. After the entire air conditioning system (and furnace system) is installed, check each position function.

6536-335\* 2-STAGE HEAT PUMP THERMOSTAT OPERATION TABLE

	Mode Switch	Fan Mode Switch	Fan Speed Switch	Calling	Operation
1	Cool	Auto	Lo	No	No functions occur in this mode
2	Cool	Auto	Lo	Stage 1 1 Above Set	ID fan low, compressor #1 and OD blower low cycle as needed
3	Cool	Auto	Lo	Stage 2 2 Above Set	ID fan low, compressor #1 & #2 and OD blower high cycle as needed
4	Cool	On	Lo	No	ID fan low continuous
5	Cool	On	Lo	Stage 1 1 Above Set	ID fan low continuous, compressor #1 and OD blower low cycle as needed
6	Cool	On	Lo	Stage 2 2 Above Set	ID fan low continuous, compressor #1 & #2 and OD blower high cycle as needed
7	Cool	Auto	Hi	No	No functions occur in this mode
8	Cool	Auto	Hi	Stage 1 1 Above Set	ID fan high, compressor #1 and OD blower low cycle as needed
9	Cool	Auto	Hi	Stage 2 2 Above Set	ID fan high, compressors #1 & #2 and OD blower high cycle as needed

Figure 1

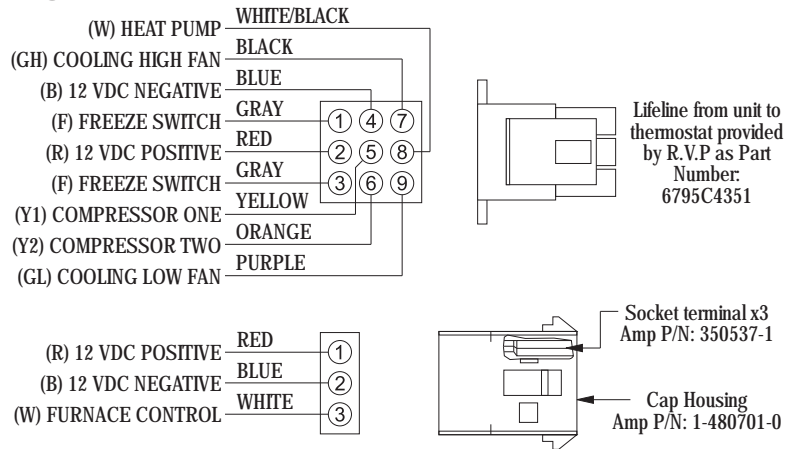

## NOTE 2

### Heat Pump Example To Bring On Gas Furnace as Backup Heat

Setpoint	Indoor Temp.	Operation
70	70+	No functions occur
	69	Heat Pump turns on (Primary heat source)
	71	Heat Pump turns off (Thermostat satisfied)
	69	Heat Pump turns on
	65	Gas Furnace turns on, heat pump turns off (Heat Pump not able to satisfy Thermostat) (First strike for backup heat counter)
	71	Gas Furnace turns off (Thermostat satisfied)
	69	Heat Pump turns on
	65	Gas Furnace turns on, heat pump turns off (Heat Pump not able to satisfy Thermostat) (Second strike for backup heat counter)
	71	Gas Furnace turns off (Thermostat satisfied)
	69	Heat Pump turns on
	65	Gas Furnace turns on (Heat Pump is again unable to satisfy Thermostat), (backup heat counter reaches 3 <sup>rd</sup> strike and Heat Pump is locked out for 1 hour + 45 minutes), <b>backup heat counter is reset if Heat Pump is running for more than 20 minutes and does not call for backup heat</b>
	71	Gas Furnace turns off (Thermostat satisfied)
	69	Gas Furnace turns on (Becomes Primary heat source)
	71	Gas Furnace turns off (Thermostat Satisfied) <b>After 1 hour + 45 minutes lockout</b>
	69	Heat Pump turns on (Resumes as Primary heat source)
	65	Gas Furnace turns on, heat pump turns off (Becomes primary heat source) (Heat Pump is locked out for another 1 hour + 45 minutes)
	71	Gas Furnace turns off (Thermostat Satisfied) <b>After 1 hour + 45 minutes hour lockout</b>
	69	Heat Pump turns on (Resumes as primary heat source)
	71	Heat Pump turns off (Thermostat satisfied) <b>(backup heat counter is reset any time Heat Pump satisfies thermostat setpoint and does not need Gas Furnace)</b>

The word "DIFF" will display on LCD when backup heat is operating and the heat pump is locked out. There is a 30 second delay between Stage 1 and Stage 2. There is also a 3 minute anti-short cycle delay time for cooling.

## APPLICATION

The 6536-335\* thermostat is intended for use with an RV Products 2 stage heat pump. The thermostat connects to the heat pump with a 9 pin plug through a lifeline (RVP part number 6795C4351). The OEM (Original Equipment Manufacturer) must supply the 12 VDC wiring and the furnace control wiring which connects to the 3 pin plug on the thermostat. The OEM supplies the mating receptacle for the 3 pin plug. RV Products suggests the thermostat wiring be minimum 18 gauge. The furnace control circuit must not exceed 1 amp. The thermostat is equipped with a replaceable fast-acting 2 amp fuse located on the base of the thermostat. The fuse is designed to "open" if the furnace is mis-wired or there is a short in the system. Before replacing fuse, the cause of the failure must be located and corrected.

## INSTALLATION INSTRUCTIONS

**BE SURE ALL ELECTRICAL POWER HAS BEEN DISCONNECTED FROM THE HEAT PUMP AND THE POWER SUPPLY.**

These instructions are provided for the proper mounting of the thermostat itself. An Operation Chart (pages 2&3) is provided to show thermostat capabilities.