



RV Products Division

**COLEMAN-MACH
DATA INQUIRY SHEET
482X7-8XX**

Capacity (Nominal BTUH)	Cooling 11,000 Heating (1) 5,600
Electrical Rating	115 VAC, 60 HZ, 1 Phase
Cooling Full Load AMP's at A.R.I. Standard Condition	Compressor 7.0 Fan Motor Low - 2.7 High - 2.9 Total 9.3 9.9
Feature Equipment Amps	Heating (1) 15.6
Running Watts (cooling) A.R.I. Standard Condition (80 F. DB 67 F. WB Indoor, 95 F. DB Outdoor)	1080
Running Watts (cooling) Desert Condition (100 F. DB 72 F. WB Indoor, 120F. DB Outdoor)	1340
Running Watts (heating) (1)	1750
Compressor Locked Rotor Amps	45.6
Metering Device	Capillary Tube
Refrigerant Charge - R-410A	16.50 oz.
Evaporator Air Delivery (CFM)	320 - High Speed
Generator Size	See "Generators" Below
Unit Weight (pounds)	83.5 lbs. (2)
Use time delay fuse or circuit breaker (U.L. H.A.C.R. Type C.S.A.) Rated at 20 amps. Supply wires 12 AWG Min. (Copper)	

- (1) When equipped with Elect-A-Heat feature.
- (2) Ceiling assemblies may add an additional 3.5 to 12.5 lbs. depending on the model number.

CEILING ASSEMBLY: Any 8330 or 9330 Series

GENERATORS:

It is not the policy of Airxcel, Inc. to size generators for application in Recreation Vehicles or related structures. However, when sizing generators, the total electrical power consumption in Watts must be determined and taken into consideration, such as:

- A. Maximum running watts of the air conditioner at Airxcel, Inc. Desert Test (See Specifications).
- B. Power consumption of electronic ovens, toasters, coffeemakers, television sets, refrigerators, lights, etc.
- C. Generators do lose capacity under the following conditions: (1) Altitude increases above sea level, (2) Temperature increases above certain outdoor design temperatures, and (3) Lack of maintenance.

**Airxcel Inc.
RV Products Division
P.O. Box 4020
Wichita, KS 67204**

ROOF TOP UNIT DIMENSIONS

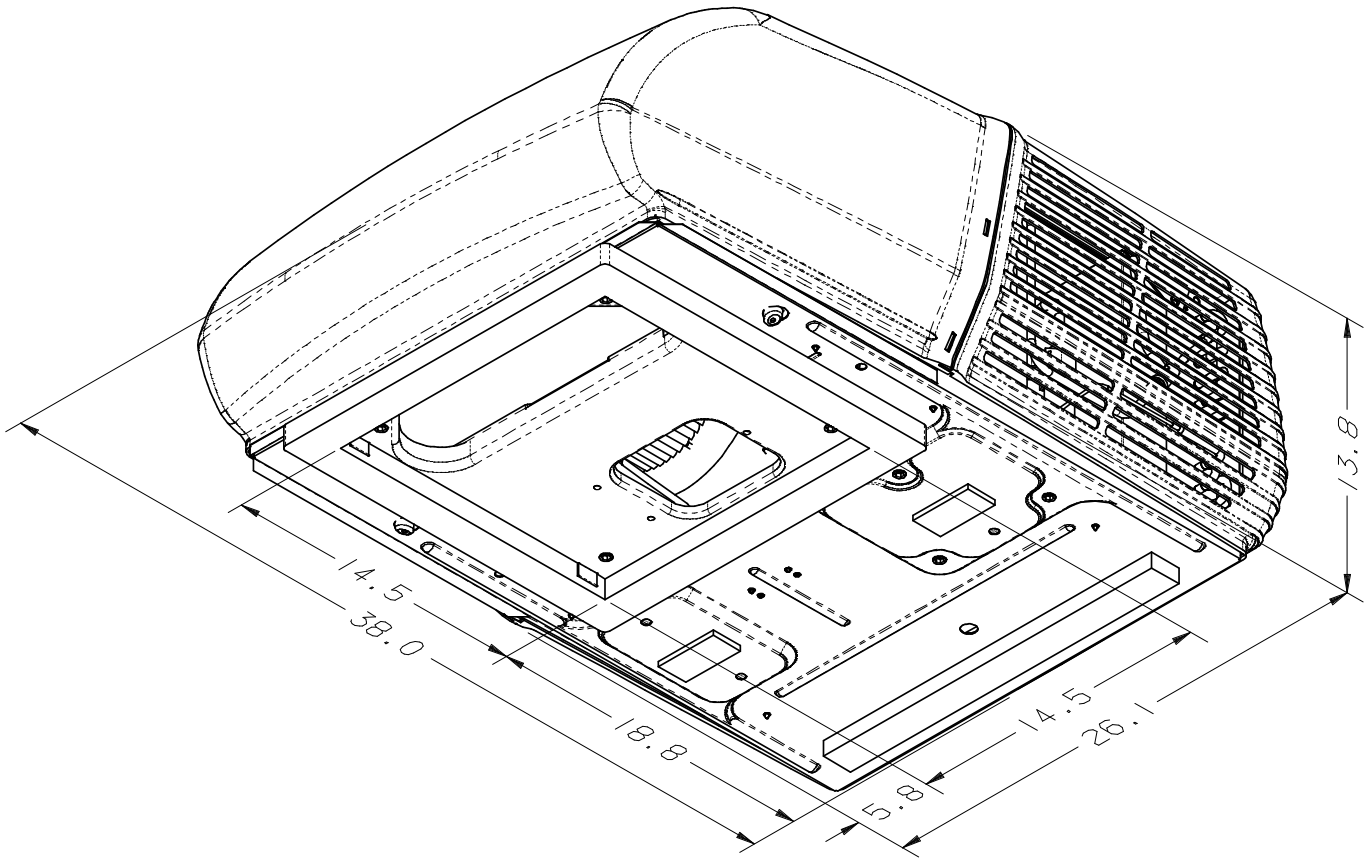

QUICK REFERENCE CHART

DIMENSIONS	
Exterior Shroud	Height 13.8
	Width 26.1
	Length 38.0
Interior Shroud	Depth 2.2
	Width 19.9
	Length 20.1

CEILING SHROUD DIMENSIONS

