



RV Products Division

**COLEMAN-MACH  
DATA INQUIRY SHEET  
482X3-8XX**

Capacity (Nominal BTUH)	Cooling 13,500 Heating (1) 5,600
Electrical Rating	115 VAC, 60 HZ, 1 Phase
Cooling Full Load AMP's at A.R.I. Standard Condition	Compressor 11.9 Fan Motor Low - 2.7 High - 3.4 Total 14.6 15.3
Feature Equipment Amps	Heating (1) 16
Running Watts (cooling) A.R.I. Standard Condition (80 F. DB 67 F. WB Indoor, 95 F. DB Outdoor)	1650
Running Watts (cooling) Desert Condition (100 F. DB 72 F. WB Indoor, 120F. DB Outdoor)	1900
Running Watts (heating) (1)	1800
Compressor Locked Rotor Amps	63
Metering Device	Capillary Tube
Refrigerant Charge - R-410A	12.50 oz.
Evaporator Air Delivery (CFM)	320 - High Speed
Generator Size	See "Generators" Below
Unit Weight (pounds)	79.5 lbs. (2)
Use time delay fuse or circuit breaker (U.L. H.A.C.R. Type C.S.A.) Rated at 20 amps. Supply wires 12 AWG Min. (Copper)	

- (1) When equipped with Elect-A-Heat feature.
- (2) Ceiling assemblies may add an additional 3.5 to 12.5 lbs. depending on the model number.

**CEILING ASSEMBLY:** Any 8330, 9330, 7330B751, -755 and 7530B750

**GENERATORS:**

It is not the policy of Airxcel, Inc. to size generators for application in Recreation Vehicles or related structures. However, when sizing generators, the total electrical power consumption in Watts must be determined and taken into consideration, such as:

- A. Maximum running watts of the air conditioner at Airxcel, Inc. Desert Test (See Specifications).
- B. Power consumption of electronic ovens, toasters, coffeemakers, television sets, refrigerators, lights, etc.
- C. Generators do lose capacity under the following conditions: (1) Altitude increases above sea level, (2) Temperature increases above certain outdoor design temperatures, and (3) Lack of maintenance.

**Airxcel Inc.  
RV Products Division  
P.O. Box 4020  
Wichita, KS 67204**

## ROOF TOP UNIT DIMENSIONS

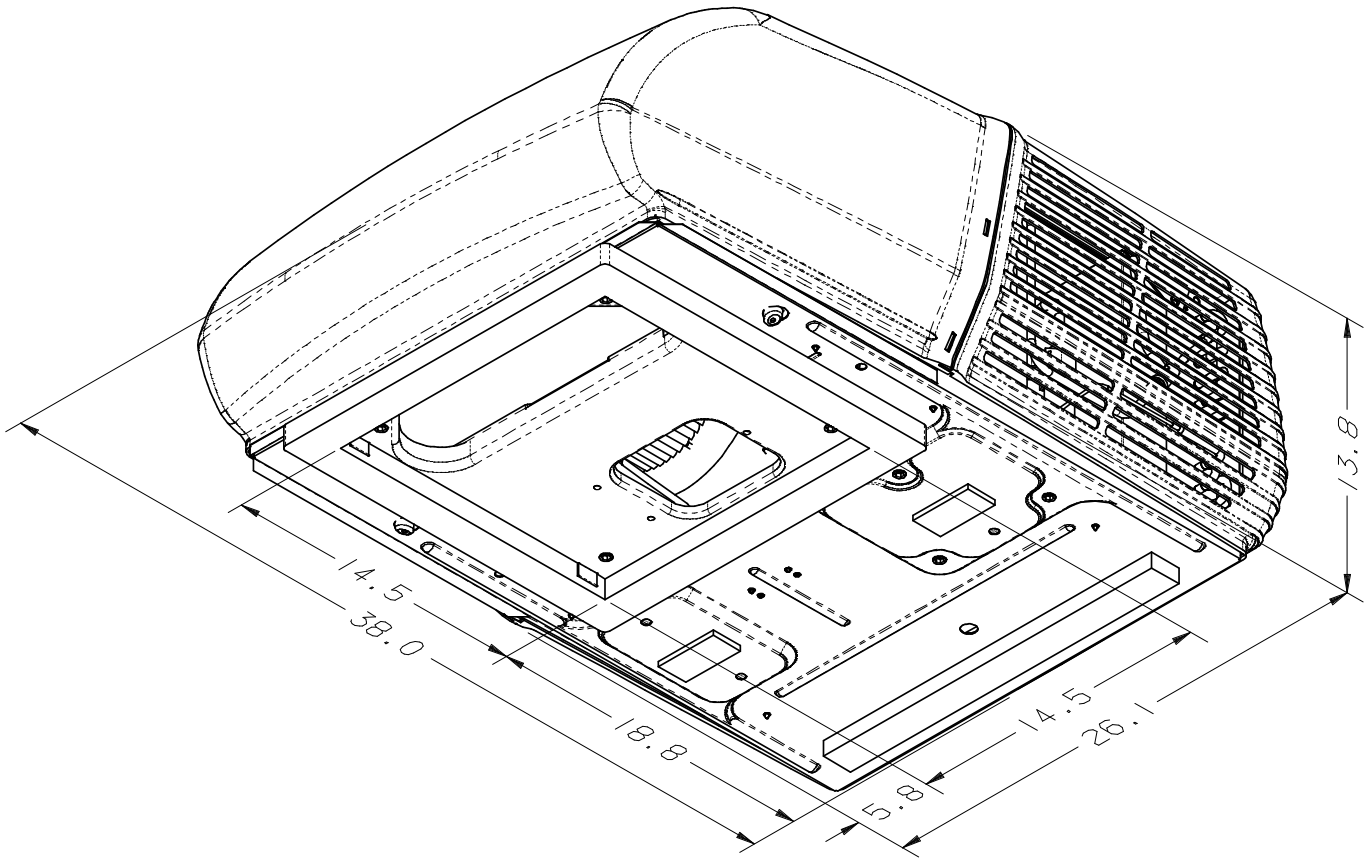

### QUICK REFERENCE CHART

DIMENSIONS	
Exterior Shroud	Height 13.8
	Width 26.1
	Length 38.0
Interior Shroud	Depth 2.2
	Width 19.9
	Length 20.1

### CEILING SHROUD DIMENSIONS

