



**RV Products Division**

## **INSTALLATION INSTRUCTIONS**

**FOR**

### **8330-5501 MOUNTING KIT**

**8330-752 CONTROL BOX KIT (12 VDC COOL ONLY)**

**9330B755 CONTROL BOX KIT (12 VDC HEAT/COOL)**

**8530-750 CONTROL BOX KIT (24 VAC COOL ONLY)**

**9530A751 CONTROL BOX KIT (12 VDC HEAT PUMP)**

**9530A755 CONTROL BOX KIT (12 VDC HEAT PUMP)**

**WITH BACKUP ELECTRIC HEAT**

**8330B751 ZONE CONTROL KIT (12 VDC COOL ONLY)**

**8330C755 ZONE CONTROL KIT (12 VDC HEAT/COOL)**

**8530C751 ZONE CONTROL KIT (12 VDC HEAT PUMP)**

# TABLE OF CONTENTS

1.	Warnings .....	2
2.	General Information and Requirements .....	2
3.	Package Contents .....	3
4.	System Match-Up, Grilles and Filters .....	3
5.	Ceiling Plenum Installation Requirement .....	4
6.	Control Box Kits .....	5
7.	Control Box Kits (Zone) .....	5
8.	Wall Thermostats .....	5
9.	Supply Ducting and Registers .....	5
10.	Routing Thermostat Wiring .....	6
11.	Routing Thermostat Wiring (Zone) .....	6
12.	Routing 115 VAC Wiring .....	7
13.	Ceiling Plenum Mounting .....	8
14.	Installing the Control Box .....	8
15.	Installing the Control Box (Zone) .....	9
16.	Installing the Heater Assembly .....	11
17.	Install Air Grille Assembly .....	12

## 1. WARNINGS

### IMPORTANT NOTICE

These instructions are for the use of qualified individuals specially trained and experienced in installation of this type equipment and related system components.

Installation and service personnel are required by some states to be licensed. **PERSONS NOT QUALIFIED SHALL NOT SERVICE THIS EQUIPMENT.**

### WARNING

Improper installation may damage equipment, can create a hazard and will void the warranty.

The use of components not tested in combination with these units will void the warranty, may make the equipment in violation of state codes, may create a hazard and may ruin the equipment.

### WARNING – SHOCK HAZARD

To prevent the possibility of severe personal injury or equipment damage due to electrical shock, always be sure the electrical power to the appliance is disconnected during installation.

**CAREFULLY FOLLOW ALL INSTRUCTIONS AND WARNINGS IN THIS BOOKLET TO AVOID DAMAGE TO THE EQUIPMENT, PERSONAL INJURY OR FIRE.**

### NOTE

**The words “Shall” or “Must” indicate a requirement which is essential to satisfactory and safe product performance.**

**The words “Should” or “May” indicate a recommendation which is not essential and not required, but which may be useful or helpful.**

## 2. GENERAL INFORMATION AND REQUIREMENTS

This mount kit is designed to provide fore and aft (straight through) ducting. It is applicable to **48000 or 49000 Series Roof Top Units Only**. The control box mounts inside the upper unit return air opening. Minimum recommended duct size is 2 1/2" x 6". Supply registers should have an accumulated minimum discharge area of 48 square inches. The manufacturer supplied ducting must be insulated and covered with a vapor barrier to prevent ceiling condensate

staining. Insulation above the duct will minimize heat gain from the roof. The minimum recommended roof thickness with this system is 3 1/2". The upper unit and ceiling assembly mount on a square roof opening 14" to 15" on a side. The roof must be capable of supporting 110 pounds of static load. Keep in mind that dynamic loads exist in recreation vehicles.

The flush mount ceiling plenum is designed for application in systems that utilize field fabricated (OEM supplied) cold air ducting. The ducting must be routed through the ceiling cavity (between the interior ceiling and roof). Ducting specifications are given in the section labeled "Supply Ducting and Registers".

This system utilizes a single, non-ducted centrally located return air opening. The return air opening is contained within the ceiling plenum. The ceiling plenum must be located directly below the roof opening used for mounting the roof top unit.

All manual controls have been removed from the ceiling plenum. They have been replaced with control relays. The relays are mounted in the electrical box of the ceiling plenum. The relays contain 12 VDC coils (which may be energized by a wall mounted thermostat), with contacts that control the 115 VAC used to power the roof top unit.

A low voltage controller controls all air conditioning functions. The low voltage controller controls a 12 VDC electrical circuit, which is used to energize the relays in the ceiling plenum. The low voltage controller that Airxcel, Inc. provides for the system may be a combination (Heat/Cool).

These low voltage controllers are capable of operating both the roof top air conditioner and any furnace with a 12 VDC control circuit of 1 amp or less (continuous current).

All air conditioning equipment is subject to freeze-up when evaporator air flow is sufficiently reduced. Ducting of any length creates potential for reduced evaporator air flow and system freeze-up. To protect both the installer and Airxcel, Inc. from conditions that promote reduced air flow and system freeze-up, Airxcel, Inc. has equipped the ceiling plenum compressor control circuit with a low temperature probe. The low temperature probe monitors the temperature of the air conditioner evaporator coil. When the temperature of the evaporator coil drops below 28 degrees F, the switch will open, stopping compressor operation. Compressor operation will resume once the evaporator warms to 55 degrees F.

**IMPORTANT**

**The low temperature sensor is part of the ceiling plenum electrical circuit. The probe must be inserted into the evaporator coil of the roof top unit by the installer when bolting the ceiling plenum to the roof top unit.**

**3. PACKAGE CONTENTS**

The mounting kit package contains the following:

- 1) Steel Mount Frame
- 2) Fiberglass Divider Board
- 3) Insulated Supply Duct
- 4) Small Parts Package Consisting Of:
  - a) Mounting bolt (x4)
  - b) Mount screws (x11)

**4. SYSTEM MATCH-UP, GRILLES AND FILTERS**

Ceiling Assembly Desired Function	Control Box Kit	Wall Thermostat
12 VDC Control – Cooling Only	8330-752	7330G3351 or 8330-3362
12 VDC Control Cool with Electric Heat	9330B755	7330G3351 or Δ 8530A3451
24 VAC Control – Cooling Only	8530-750	7330B3441 or 8330A3241
12 VDC Control – Heat Pump	9530A751 or 9530A755	8530A3451
12 VDC Zone Control – Cooling Only	8330B751	8330D3351
12 VDC Zone Control Cool with Electric Heat	8330C755	8330D3351
12 VDC Zone Control – Heat Pump	8530C751	8330D3351

Δ Use if thermostat is to operate 12 VD furnace (See Notes)

16” Grilles and Filters

- 6798-3041 White Grille
- 6798-3042 White Grille (25 Pack)
- 6798A3761 Filter
- 6798A3762 Filter (25 Pack)

18” Grilles and Filters

- 6798-3091 White Grille
- 6798-3092 White Grille (25 Pack)
- 6798-3751 Filter
- 6798-3752 Filter (25 Pack)

## NOTES

The sub-base will allow thermostat control of the electric heater in the upper unit or a 12 VDC controlled furnace with a control load of one amp or less. The user slide switch selects the heat source desired. A low temperature override will automatically switch in the gas furnace if the thermostat is

calling for electric heat and the conditioned space heat loss is greater than the electric heat capacity. This feature has been provided to prevent freeze-up of the conditioned space in the event that no user is present to select gas heat during a drop in temperature.

## 5. CEILING PLENUM INSTALLATION REQUIREMENT

1. The ceiling plenum must be installed under the roof opening.

The ceiling plenum bolts below the roof top unit. Compression of the framed ceiling cavity between the roof top unit and the ceiling plenum is what holds both components in place.

2. Ceiling cavity depth (the measurement from the ceiling to the roof – maximum 6”).
3. Provided with the ceiling plenum is a divider board which is used to separate the conditioned air from the return air supply.
4. The 115 VAC service for the roof top unit must be routed into the ceiling plenum. To prevent wire pinching and to promote ease of installation, allowances must be made for routing the 115 VAC supply wiring into the front of the roof opening.
5. The wirebox has a 9 pin receptacle extending from the front. This mates with the roof unit 115 volt

electrical conduit. When making this connection, verify that the plugs are properly aligned and have snapped together securely.

6. The wirebox for the heat/cool units will have a two pin receptacle which mates with the umbilical plug from the heater assembly.
7. **LOW VOLTAGE CONTROL WIRING (WALL THERMOSTAT)**
  - A. A low voltage terminal strip on the front of the box connects to the low voltage control wires. The wires attach by 1/4" quick connects.
  - B. The low voltage control wiring must be run from the wall thermostat mounting location to the wirebox low voltage terminals. To prevent wire pinching and to promote ease of installation, allowances must be made for routing the low voltage wiring into the front of the opening.

### Standard Control Box

Plenum Terminal Designation	Thermostat Wire Connection	Function of Low Voltage Terminal Extending from Ceiling Plenum
Cool Only and Heat/Cool Boxes	B	BLUE
	Y	YELLOW
	GH	GREEN
	GL	GRAY
	FREEZE	WHITE
Heat/Cool Box	W	WHITE

### Zone Control Box

Plenum Terminal Designation	Thermostat Wire Connection	Function of Low Voltage Terminal Extending from Ceiling Plenum
R+	Red	Provides +12 VDC to upper unit control box
Cool Shed (2 terminals)	White Jumper Wire	Removing jumper wire will allow system to be connected to N.C. contacts of a load shed system
Heat Shed (2 terminals)	White Jumper Wire	Removing jumper wire will allow system to be connected to N.C. contacts of a load shed system
Room (2 terminals)	Any	The remote room temperature sensor attaches here*
Freeze (2 terminals)	White	Freeze sensor attaches here
Gen	Any	Allows system to connect to an automatic start generator system
B-	Blue	Provides -12 VDC to upper unit control box
Sig	Purple	Communication line between upper unit control box and thermostat

\* Zone 1 has option of using thermostat as room sensor

## 6. CONTROL BOX KITS

### 1. 8330-752 – 12 VDC Controlled, Cool Only

This kit consists of a control box assembly. The evaporator freeze sensor is shipped in an envelope for installation by quick connects to terminal strip “Freeze”.

### 2. 9330B755 – 12 VDC Controlled, Heat/Cool

This kit consists of a control box assembly. The evaporator freeze sensor is shipped in an envelope for installation by quick connects to terminal strip “Freeze”. A heater assembly is also packed with the kit.

### 3. 8530-750 – 24 VAC Controlled, Cool Only

This kit is similar to the 8330-752 with the exception of a transformer that is attached to the box assembly.

### 4. 9530A755 – 12 VDC Controlled, Heat Pump With Backup Electric Heat

This kit is similar to the 9330B755 but is wired for the heat pump function.

### 5. 9530A751 – 12 VDC Controlled, Heat Pump

This kit is the same as the 9530A755 except without the electric heat assembly.

## 7. CONTROL BOX KITS (ZONE)

### 1. 8330B751 – 12 VDC Zone Controlled, Cool Only

This kit consists of a control box assembly. The evaporator freeze sensor is shipped in an envelope for installation by quick connects to terminal strip marked “FREEZE”.

### 2. 8330C755 – 12 VDC Zone Controlled, Heat/Cool

This kit consists of a control box assembly and a heater assembly. The evaporator freeze sensor is shipped in an envelope for installation by quick connects to terminal strip marked “FREEZE”.

### 3. 8530C751 – 12 VDC Zone Controlled, Heat Pump

This kit consists of a control box assembly. The evaporator freeze sensor is shipped in an envelope for installation by quick connects to terminal strip marked “FREEZE”. Backup electric heat is available as an optional kit (part number 9233\*4551).

## 8. WALL THERMOSTATS

1. Locate and install the thermostat per instructions found with the thermostat.
2. For 12 VDC thermostats, it is required that the thermostat 12 volt negative connection be routed directly from the converter or battery. It is highly desirable to provide 12 volt control power from the battery side of the converter. These precautions should prevent control problems.

3. For the 24 VAC thermostat, keep in mind that if the application will involve operation while in motion or subject to vibration, an electromechanical thermostat must not be used as electromechanical contacts will “chatter” the compressor relay if used in high vibration applications. For applications subject to vibration, an electronic wall thermostat must be used. (See System Match-Up for Airxcel, Inc. part numbers.)

## 9. SUPPLY DUCTING AND REGISTERS

### A. Ducting

1. The field fabricated supply ducting must open into both ends of the ceiling plenum. Two ducts are required; one duct attached to the front, and one to the rear of the plenum (See Figure 1).
2. Each duct must have a minimum height of 1 1/2", maximum height cannot exceed 4 inches.

Total free area inside each duct must be no less than 10 square inches.

### NOTE

To decrease restriction and increase air flow, the ducting should make as few bends and turns are possible. When corners or turns are required, we recommend that you radius the corners to keep air flow at a maximum.

Ten (10) square inches of free area per duct is the minimum requirement, larger ducting will improve air flow and system performance.

3. Where ducting secures to the ceiling plenum, maximum width is 6 inches.
4. All field fabricated cold air supply ducting must be insulated and must have a vapor barrier.

## IMPORTANT

**Insulation reduces cooling loss and helps prevent water staining of the vehicle ceiling due to moisture condensation.**

### B. Registers

Supply (cold air) registers should have a minimum discharge area of 48 square inches per system, or 24 square inches per duct. A minimum of 6 is recommended.

## 10. ROUTING THERMOSTAT WIRING

1. Following the instructions packed with the thermostat, determine a location for thermostat mounting.
2. Following Airxcel, Inc. low voltage wiring specifications and all local and national electrical codes:
  - A. Route the thermostat 12 VDC supply wiring from the power source to the thermostat mounting location.  
  
Two wires are required:  
  
One supply lead must be +12 VDC and red in color.  
  
The second supply lead must be -12 VDC and blue in color.
  - B. To protect the wall mount thermostat from over-current damage, a 2 amp fuse has been provided with the thermostat.

- C. Route the thermostat control wiring from the thermostat mounting location into the front of the ceiling plenum opening.

Four (4) wires are required (5 wires for heat/cool boxes). These wires are as follows:

- (1) Blue wire for -12 VDC circuit
- (1) Yellow wire for compressor circuit
- (1) Green wire for high fan circuit
- (1) Gray wire for low fan circuit
- (1) White wire for heat circuit

3. Airxcel, Inc. low voltage wiring specifications:

- A. All low voltage wiring should be 18 gauge minimum.
- B. Low voltage wiring must be routed into the front side of the ceiling plenum opening.

## 11. ROUTING THERMOSTAT WIRING (ZONE)

1. Following the instructions packed with the thermostat, determine a location for thermostat mounting.
2. Following Airxcel, Inc. low voltage wiring specifications and all local and national electrical codes:
  - A. Route the thermostat control wiring from the thermostat mounting location into the front of the ceiling plenum opening.  
  
These wires are as follows:
    - (1) Red wire to +12 VDC circuit (R+)
    - (1) Blue wire for -12 VDC circuit (B-)
    - (1) Purple wire to communication signal (Sig)

- (1) Any color for auto generator start (optional) (Gen)
- (2) Any color for room temperature sensor (zone 1 optional, required for other zones)
- (1) Any color for each heating appliance (Up to 4)
- (2) Any color for cool load shed (optional)
- (2) Any color for heat load shed (optional)

- B. See Figure 5 for wiring requirements for multiple zones.

3. Airxcel, Inc. low voltage wiring specifications:
  - A. All low voltage wiring should be no smaller than 18 gauge.
  - B. Low voltage wiring must be routed into the front side of the ceiling plenum opening.

- C. Low voltage wiring should not be routed with high voltage wiring.
- D. If low voltage and high voltage wires must cross, they should do so at right angles from one another.

## 12. ROUTING 115 VAC WIRING

Following Airxcel, Inc. high voltage wiring specifications and all local and national electrical codes, route the roof top unit 115 VAC supply wiring from its power source and into the front of the roof top opening. Allow approximately 12" of the wiring into the opening.

2. To prevent voltage drops greater than 10% during starting, adhere to the following guideline:

For lengths greater than 50', use #10 AWG.

Circuit Protection – Refer to upper unit nameplate.

### High Voltage Wiring Specifications

1. U.L. approval requires the power supply to be copper conductors only with minimum #12 AWG.

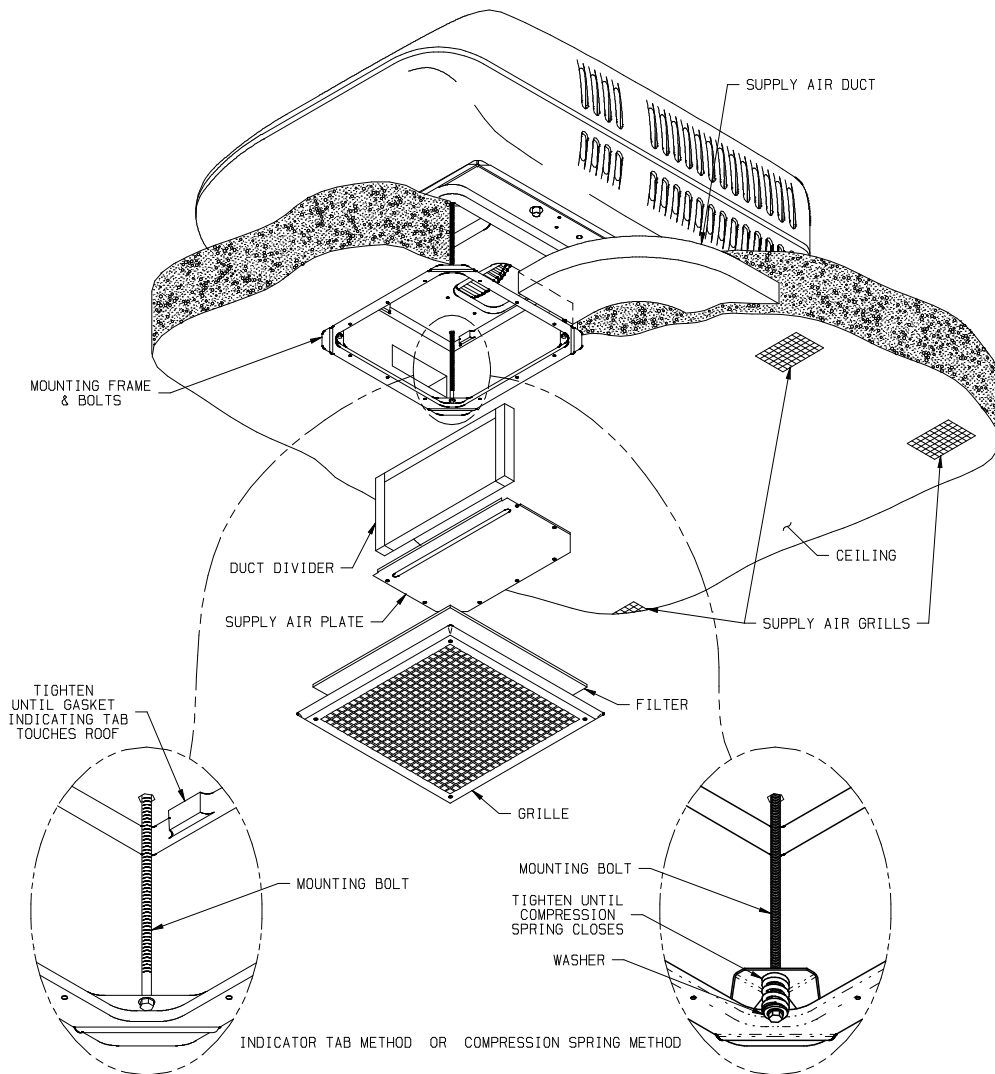

FIGURE 1

## 13. CEILING PLENUM MOUNTING

### A. Installing Unit (Refer to Figure 1).

1. Place the air conditioner over the roof opening.
2. Position the mount frame into the ceiling opening (See Figure 1).
3. Using the four bolts provided, secure the mount frame to the roof top unit. The four mounting bolts are to be applied up through the bottom of the mount frame and into the bottom of the roof top unit (See Figure 1). Tighten each bolt until the indicators of the gasket are at roof level.
4. Route the conduit into the return opening.

### B. Installing Divider Board (Refer to Figure 1).

1. Measure the distance between the ceiling and the upper unit basepan, add 1/2" to this measurement and cut the duct divider to this height if necessary. **ALWAYS CUT OFF THE BOTTOM EDGE (THE EDGE WITHOUT FOAM STRIP).**
2. Carefully wedge this divider between the walls of the roof opening and up against the upper unit basepan with the silver side facing forward. The divider should be positioned to nest vertically in 1" wide channel in insulated supply air duct.
3. Attach insulation supply air plate to the mounting frame using the screws provided with the ceiling plenum.

## 14. INSTALLING THE CONTROL BOX

1. Remove the control box assembly cover which is held by two sheet metal screws. Feed the field lead wires and ground through the strain relief found with the control box.
2. Attach black supply conductor to black "pigtail" lead, white to white, and ground to green with wire nuts provided in control box kit.
3. Insure that no bare wires can come into contact with live electrical parts and that wires cannot be pinched between the control box sides and lid. Insert the strain relief into the control box entry hole to secure the field wiring. Reinstall the control box lid.
4. Attach the thermostat wires to the control box per illustrations below:

### B. Control Box 9330B755, 9530A751 & 9530A755

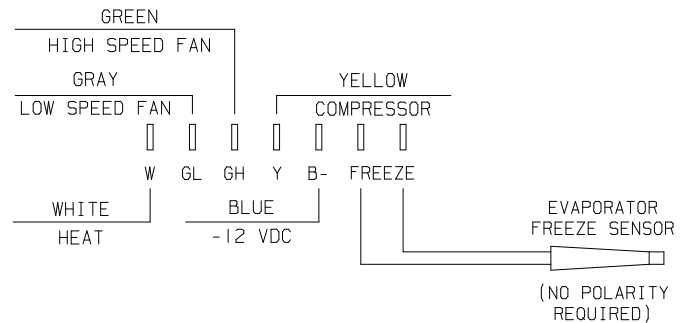

### C. Control Box 8530-750

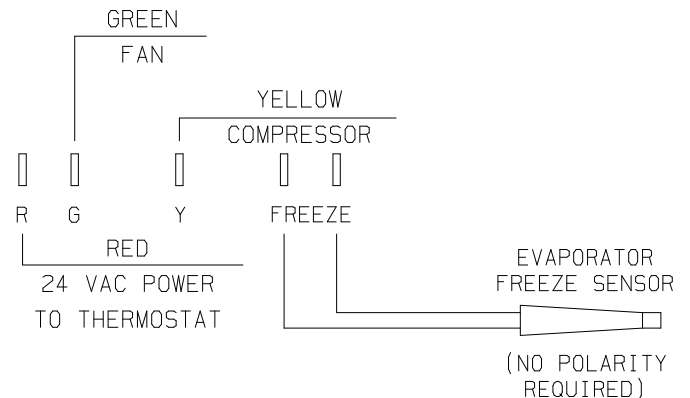

### A. Control Box 8330-752

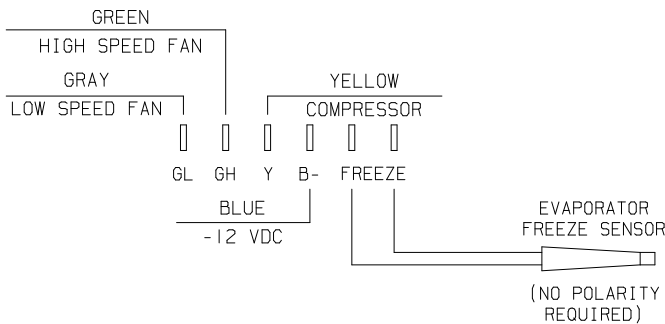

5. Connect the roof unit 115 volt electrical conduit to the wirebox 9 pin receptacle and verify that the plugs are properly aligned and have snapped together securely.

6. Locate the two machine screws inside the evaporator cover of the upper unit. Align the control box over the screws and use the wing nuts supplied with the control box to secure it to the upper unit enclosure.
7. Insert the evaporator freeze sensor between evaporator fins near the bottom center of the evaporator and between the bottom two tubes (See Figure 2). Insert straight in until contacting the staggered tube directly in back of the insertion point. When contact has been made, elevate the exposed end of the sensor approximately 45 degrees, then continue insertion at a 45 degree angle until the sensor is completely embedded into the evaporator.

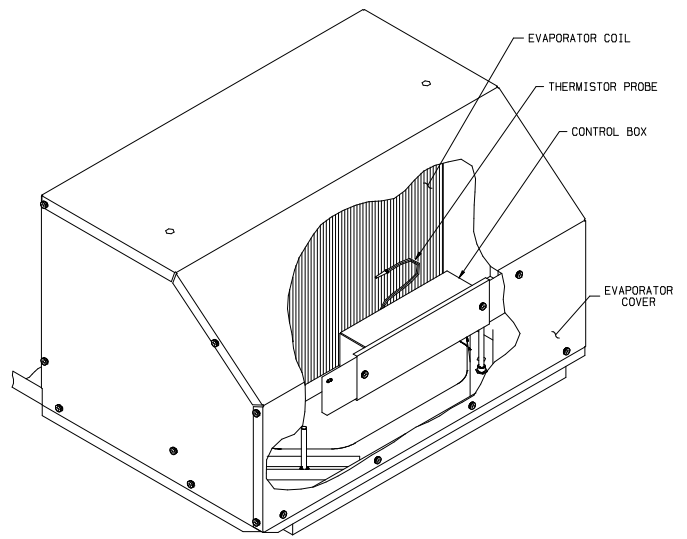

FIGURE 2

## 15. INSTALLING THE CONTROL BOX (ZONE)

All control boxes install by one of two methods.

1. Remove the control box assembly's cover which is held by two sheet metal screws.
2. Set the "zone" jumper to the proper zone position for the particular position the air conditioner or heat pump will be in the coach (**Refer to Figure 3-Zone 1 is shown**). Zones should be numbered from the front to the back of the coach with Zone 1 in front.
3. Set the "HP"/"NON HP" jumper to "HP" if the unit is a heat pump or to "NON HP" if the unit is not a heat pump (**Refer to Figure 3 – Non HP is shown**).
4. Feed the field lead wires and ground through the strain relief found with the control box then through the 7/8" hole in the side of the box.

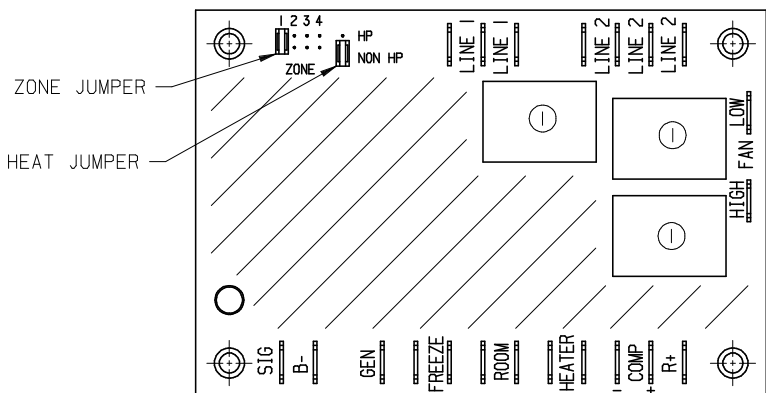

FIGURE 3

6. Wire nut the white 12-gauge field power conductor to the stripped white 12-gauge wire in the control box.
7. Wire nut the ground field power conductor to the stripped green ground wire in the control box.
8. Insure that no bare wires can come into contact with live electrical parts and that wire cannot be pinched between the control box sides and lid. Insert the strain relief into the control box entry hole to secure the field wiring. Reinstall the control box lid.
9. Mount control box in upper unit return air compartment.

Attach the thermostat wires to Zone 1 control box per the illustration below (Refer to Figure 4):

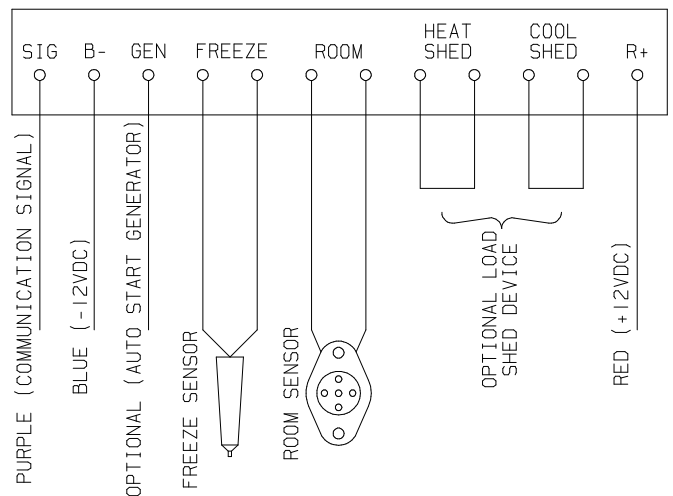
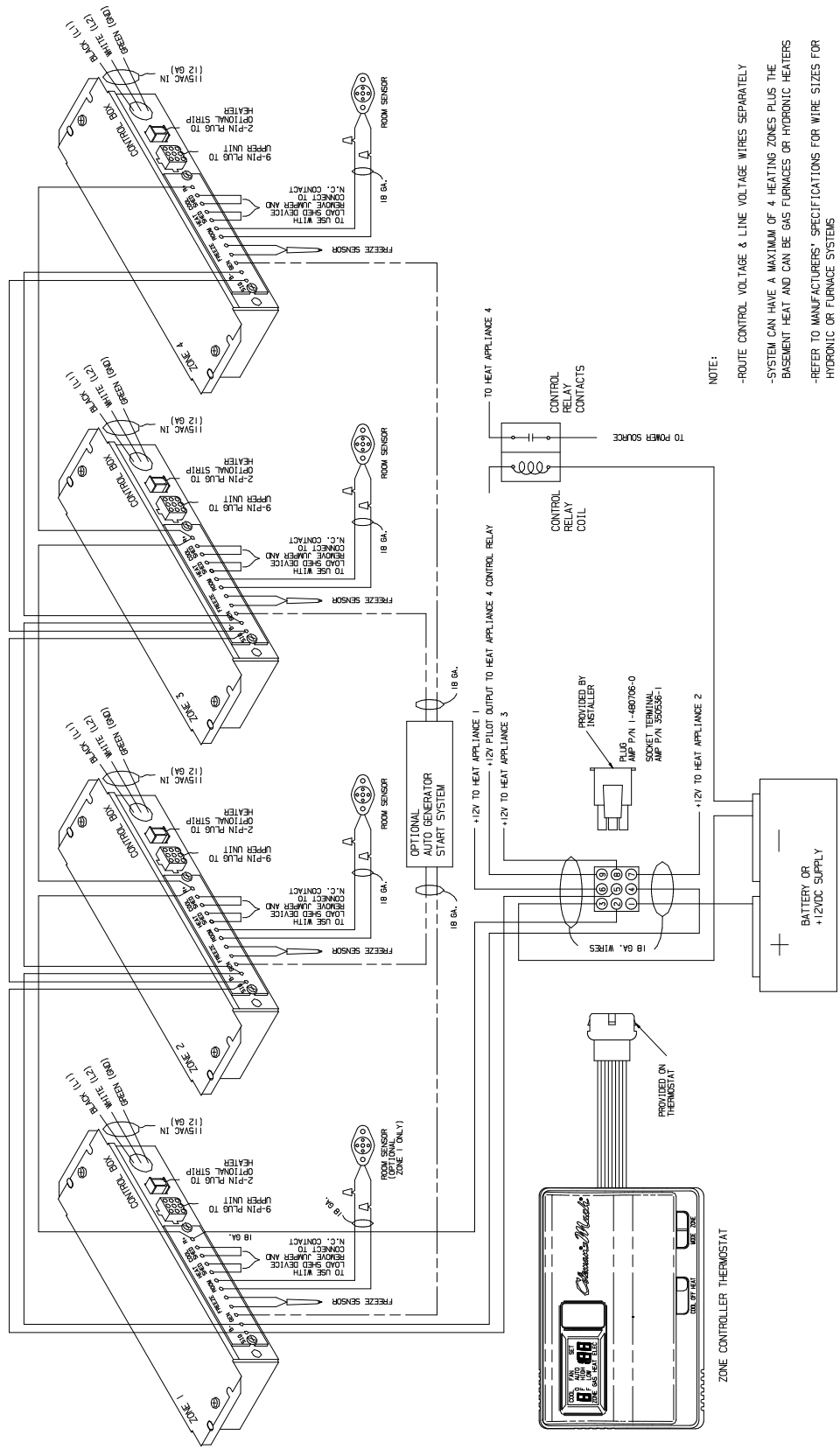

FIGURE 4

5. Wire nut the black 12-gauge field power conductor to the stripped black 12-gauge wire in the control box.



Note: The Zone System is shown with the maximum heating and cooling appliance connections.

FIGURE 5

Zone 2 is wired in by jumpering from SIG, B- and R+ on Zone 1 box to Zone 2 box. Zone 3 is wired in by jumpering from SIG, B- and R+ on Zone 2 box to Zone 3 box. Zone 4 is wired in by jumpering from SIG, B- and R+ on Zone 3 box to Zone 4 box (See Figure 5).

Connect the roof unit 115 volt electrical conduit to the wirebox 9 pin receptacle and verify that the plugs are properly aligned and have snapped together securely.

The control box will be mounted by first removing the rubber wel-nuts (if supplied with the control box) and discarding the wing bolts. Position the control box over the screws and use the rubber wel-nuts (or wing nuts if supplied) to fasten the control box to the upper unit enclosure.

Insert the evaporator freeze sensor between evaporator fins near the bottom center of the evaporator and between the bottom two tubes (See Figure 2). Insert straight in until contacting the staggered tube directly in back of the insertion point. When contact has been made, elevate the exposed end

of the sensor approximately 45 degrees, then continue insertion at a 45 degree angle until the sensor is completely embedded into the evaporator.

Complying with the warnings listed below, connect the 115 VAC supply wiring to its power source. Be sure all power remains off until beginning checkout procedure.

### **DANGER**

**TO PREVENT THE POSSIBILITY OF SHOCK INJURY FROM APPLIANCE OPERATION:**

**THE WHITE WIRE MUST BE CONNECTED TO NEUTRAL IN THE SERVICE BOX ENTRANCE AND THE MECHANICAL GROUND MUST BE CONNECTED TO A GROUNDING LUG IN THE SERVICE BOX OR THE MOTOR GENERATOR COMPARTMENT.**

## **16. INSTALLING THE HEATER ASSEMBLY**

1. The heater assembly found with the 9330B755, 9530A755 or 8330C755 control box kits can now be installed. The backup electric heater assembly is optional for control box kits 8530C751 and 9530A751. The backup electric heater assembly is available as a kit (part number 9233\*4551).
2. Position the heater assembly into the return air opening as shown in Figure 7. Insure that the set screw is retracted sufficiently to allow installation over the basepan extrusion.
3. The heater bracket **must be installed between the basepan and the plastic drain pan.** See Figure 6.
4. Tighten set screw to secure the assembly so as to prevent movement.
5. Insert the two-pin connector of the heater umbilical into the receptacle on the control box. Insure that the connector snap-locks into position.

**TIE ALL WIRING TO INSURE NO CONTACT WITH THE HEATER OR ANY SHARP EDGES. KEEP IN MIND THAT HIGH VELOCITY AIR WILL BE ENCOUNTERED IN THIS AREA.**

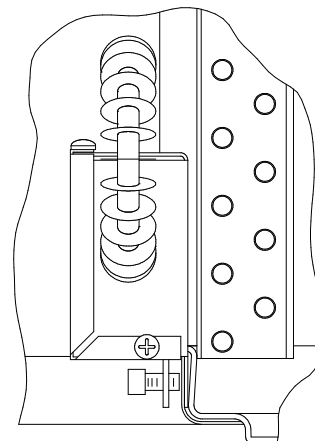

**FIGURE 6**

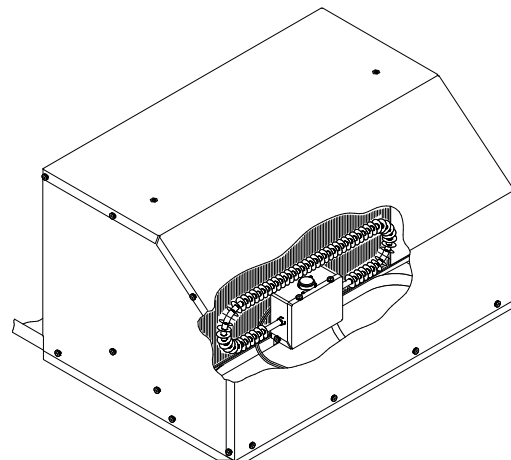

**FIGURE 7**

## **17. INSTALL AIR GRILLE ASSEMBLY**

Lift grille into position, centered over roof opening. Insert one screw into each corner of the grille and secure to ceiling.

**Airxcel, Inc.  
RV Products Division  
P.O. Box 4020  
Wichita, KS 67204**