



INSTALLATION INSTRUCTIONS

FOR 7370A736

FLUSH MOUNT CEILING PLENUM

TABLE OF CONTENTS

Warnings	2
Package Contents	2
General Information	3
Ceiling Plenum Installation Requirement	3
Supply Ducting And Registers	4
Routing Thermostat Wiring	6
Routing 240 VAC Wiring	6
Preparation And Positioning The Roof Top Unit	7
Installation Of Heater Assembly	7
Ceiling Plenum Preparation And Mounting	8
Connect 240 VAC Wiring	9
Connect Thermostat Wiring	10

WARNINGS

IMPORTANT NOTICE

These instructions are for the use of qualified individuals specially trained and experienced in installation of this type equipment and related system components.

Installation and service personnel are required by some states to be licensed. PERSONS NOT QUALIFIED SHALL NOT SERVICE THIS EQUIPMENT.

WARNING

Improper installation may damage equipment, can create a hazard and will void the warranty.

The use of components not tested in combination with these units will void the warranty, may make the equipment in violation of state codes, may create a hazard and may ruin the equipment.

WARNING - SHOCK HAZARD

To prevent the possibility of severe personal injury or equipment damage due to electrical shock, always be sure the electrical power to the appliance is disconnected.

CAREFULLY FOLLOW ALL INSTRUCTIONS AND WARNINGS IN THIS BOOKLET TO AVOID DAMAGE TO THE EQUIPMENT, PERSONAL INJURY OR FIRE.

NOTE

The words “Shall” or “Must” indicate a requirement which is essential to satisfactory and safe product performance.

The words “Should” or “May” indicate a recommendation which is not essential and not required, but which may be useful or helpful.

PACKAGE CONTENTS

- | | |
|---|---------------------------------------|
| 1) Ceiling Plenum | 1) Small Parts Package Consisting Of: |
| 1) Intermediate Length Adjustable Divider | a) Flat Washer (x4) |
| 1) Extended Length Adjustable Divider | b) Mounting Bolt (x4) |
| 1) Adjustable Divider Installation | c) Divider Screws (x2) |
| 1) Return Air Grille | d) Wirebox Strain Relief |
| 1) Return Air Filter | e) Freeze Sensor Thermistor |
| | 1) Basepan Foam Pad |
| | 1) Heater Assembly |

GENERAL INFORMATION

The flush mount ceiling plenum is designed for application in systems that utilize field fabricated (OEM supplied) air ducting. The ducting must be routed through the ceiling cavity (between the interior ceiling and roof). Ducting specifications are given in the section labeled "Supply Ducting And Registers".

This system utilizes a single, non-ducted centrally located return air opening. The return air opening is contained within the ceiling plenum. The ceiling plenum must be located directly below the roof opening used for mounting the roof top unit.

All manual controls have been removed from the ceiling plenum. They have been replaced with control relays. The relays are mounted in the electrical box of the ceiling plenum. The relays contain 12 VDC coils (which are energized by a wall thermostat), with contacts that control the 240 VAC used to power the roof top unit.

All air conditioning functions are controlled by the low voltage wall mounted thermostat. The thermostat controls a 12 VDC electrical circuit which is used to energize the relays in the ceiling plenum. The thermostats that RV Products provides for the system are combination (Heat/Cool) thermostats. These thermostats are capable of operating all functions of the roof top air conditioner and any furnace with a 12 VDC control circuit

All air conditioning equipment is subject to freeze-up when evaporator air flow is sufficiently reduced. Ducting of any length creates potential for reduced evaporator air flow and system freeze-up. To protect both the installer and RV Products from conditions that promote reduced air flow and system freeze-up, RV Products has equipped the ceiling plenum compressor control circuit with a low temperature sensor. The low temperature probe monitors the temperature of the air conditioner evaporator coil. When the temperature of the evaporator coil drops below 28 degrees F, the switch will open, stopping compressor operation. Compressor operation will resume once the evaporator warms to 55 degrees F.

IMPORTANT

The low temperature sensor is wired to the ceiling plenum electrical circuit. The switch must be inserted into the evaporator coil of the roof top unit by the installer.

This flush mount ceiling plenum will mount to and operate all current production 6700 & 7000 series, 240V roof top air conditioners. In the heating mode, the roof unit fan runs at low speed only.

The temperature limiting switch provided with the heater assembly insures that heated air from the upper unit will not exceed 175 degrees F.

CEILING PLENUM INSTALLATION REQUIREMENT

- The ceiling plenum must be installed under the roof opening.

The ceiling plenum bolts to the bottom of the roof top unit. Compression of the framed ceiling cavity between the roof top unit and the ceiling plenum holds both components in place.

- Ceiling cavity depth (the measurement from the ceiling to the roof).

Divider	Range
Intermediate Length	3.25" to 4.25"
Extended Length	5.0" to 6.0"

- The 240 VAC service for the roof top unit must be routed into the ceiling plenum. To prevent wire pinching and to promote ease of installation, allowances must be made for routing the 240 VAC

supply wiring into the front of the roof opening.

- Thermostat wiring must be run from the wall thermostat mounting location to the ceiling plenum low voltage wiring leads. To prevent wire pinching and to promote ease of installation, allowances must be made for routing the low voltage wiring into the front of the opening.
- The ceiling plenum has a 9 pin socket extending from the front of the electrical box. This mates with the roof top unit 240 volt electrical conduit. When making this connection, verify that the plugs are properly aligned and have snapped together securely.
- There is also a 2 pin socket through the electrical box which connects with the heater assembly.
- A low voltage terminal strip on the front of the box connects to the thermostat wires. The wires can connect by 1/4" quick connects.

8. Provided with the ceiling plenum are two divider plates which are used to separate the warm return air from the cold supply air. Select the appropriate plate for the roof thickness in use and discard the unused divider.

IMPORTANT

Upon installation, the divider must be raised to and sealed with both the bottom of the roof unit and the sides of the roof opening. RV Products provides foam seals for this purpose. Divider plates provided represent most common existing range of roof thickness in the industry. The extended length divider may be trimmed to accommodate roof thicknesses between 4.25" and 5.0".

Ceiling Plenum Number	Plenum Wire Designation	Thermostat Wire Connection	Function of Low Voltage Terminal Strip
7370-736 (Low voltage connection)	B Y GH GL W F F	BLUE YELLOW GREEN GRAY WHITE NONE NONE	Completes -12 VDC circuit for all relay Energizes coil on Compressor Relay Energizes coil on High Fan Relay Energizes coil on Low Fan Relay Energizes coil of heat relay or energizes furnace control as selected Freeze sensor connections (no polarity required)

SUPPLY DUCTING AND REGISTERS

A. Ducting

NOTE

1. The field fabricated supply ducting must attach to both sides of the ceiling plenum. A minimum of two ducts are required, with one duct attached to each side of the plenum.

See Figures 1 and 2 for both an overhead view of the system with ducts and a ceiling plenum/ceiling cavity installation.

2. Each duct must have a minimum height of 1 1/2", maximum height cannot exceed 4 inches. Total free area inside each duct must be no less than 10 square inches.

To decrease restriction and increase air flow, the ducting should make as few bends and turns as possible. When corners or turns are required, we recommend that you radius the corners to keep air flow at a maximum.

Ten (10) square inches of free area per duct is the minimum requirement. Larger ducting will improve air flow and system performance.

3. Where ducting secures to the ceiling plenum, maximum width is 8 inches.

4. All field fabricated air supply ducting must be insulated and must have a vapor barrier.

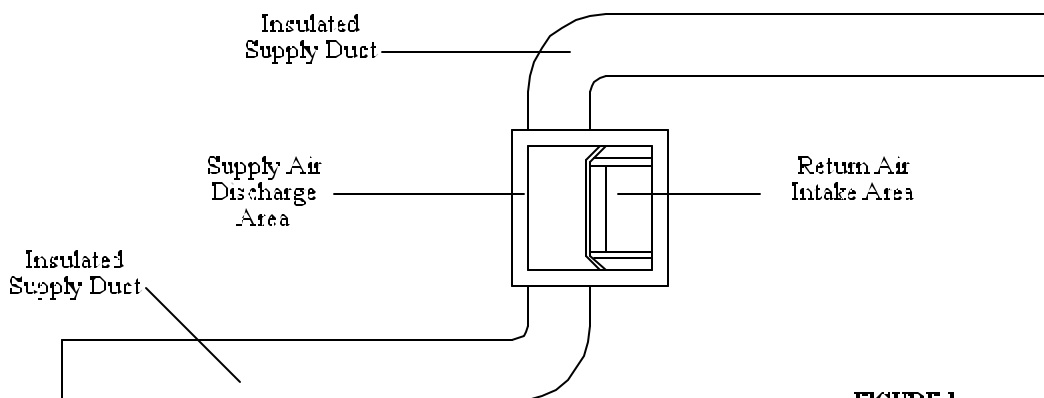

FIGURE 1

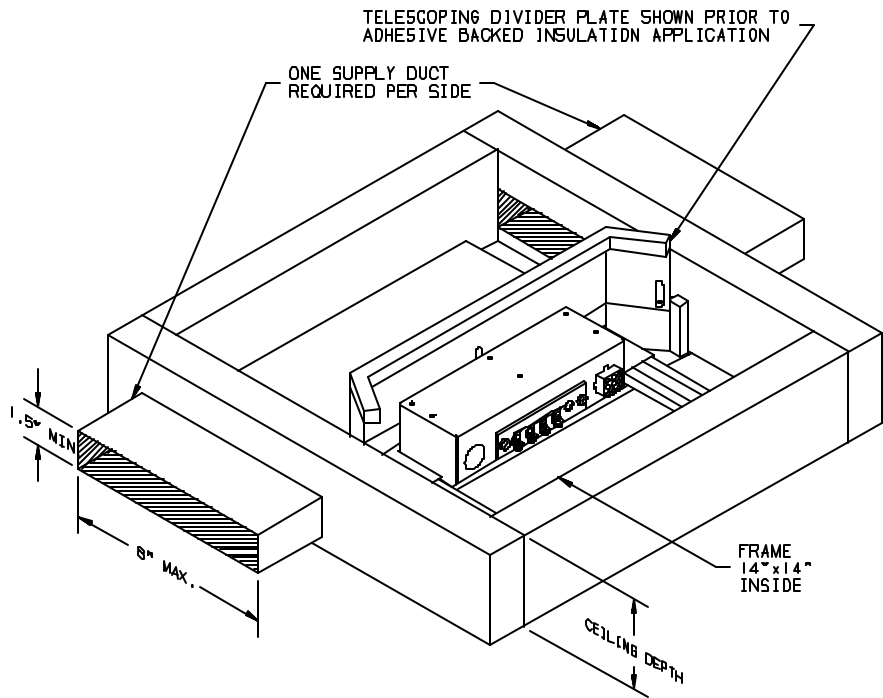

FIGURE 2

IMPORTANT

Insulating reduced cooling loss and helps prevent water staining of the vehicle ceiling due to moisture condensation.

B. Registers

1. Supply registers should have a minimum discharge area of 48 square inches per system, or 24 square inches per duct. Figure 3 shows how to determine the discharge area for a given register, and how to determine the number of registers required.

The register in Figure 3 provides 6 square inches of discharge area. Each duct would require four registers of this size to satisfy the 24" requirement.

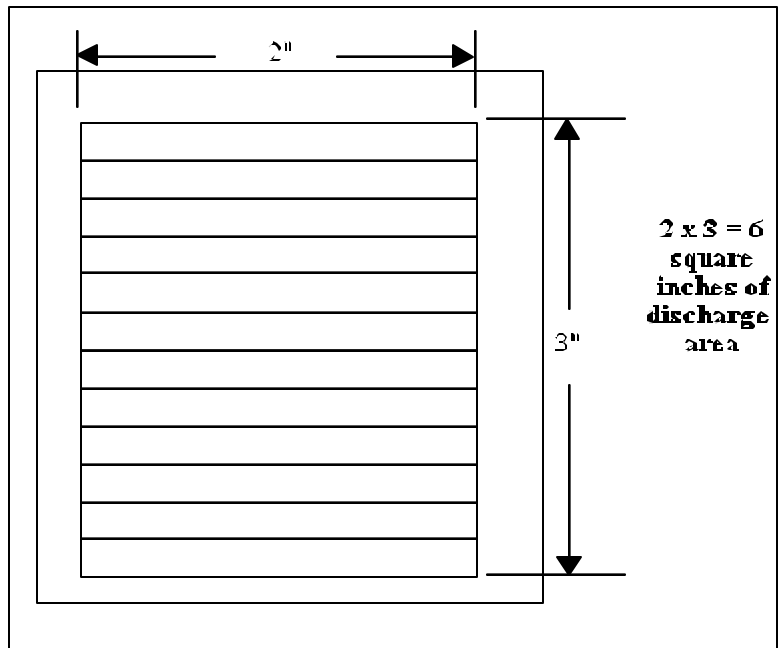

FIGURE 3

ROUTING THERMOSTAT WIRING

1. Following the instructions packed with the thermostat, determine a location for thermostat mounting.
2. Following RV Products low voltage wiring specifications and all local and national electrical codes:
 - A. Route the thermostat 12 VDC supply wiring from the power source to the thermostat mounting location.

Two wires are required:

One supply lead must be +12 VDC and should be red in color.

The second supply lead must be -12 VDC and should be blue in color.
 - B. To protect the wall mount thermostat from over current damage, a 2 amp fuse has been provided with the thermostat. It is recommended that a fuse be provided at the power supply to protect the thermostat wires up to the thermostat.
 - C. Route the thermostat control wiring from the thermostat mounting location into the front of the ceiling plenum opening.

(5) Five wires are required when using 7370A736.

These wires are as follows:

 - (1) Blue wire for -12 VDC circuit
 - (1) Yellow wire for compressor circuit
 - (1) Green wire for high fan circuit
 - (1) Gray wire for low fan circuit
 - (1) White wire for heater circuit
3. RV Products low voltage wiring specifications:
 - A. Low voltage wiring should be no smaller than 18 gauge.
 - B. Low voltage wiring must be routed into the front side of the ceiling plenum opening.

ROUTING 240 VAC WIRING

1. Following RV Products high voltage wiring specifications and all local and national electrical codes, route the roof unit 240 VAC supply wiring from its power source and into the front of the roof opening. To allow attachment to ceiling plenum high voltage connections, extend approximately 12" of the wiring into the opening.
 1. U.L. listing requires the conductors to be copper with a minimum size of 12 gauge.
 2. To prevent voltage drops greater than 10% during starting loads, adhere to the following guideline:

For lengths greater than 100', use #10 AWG.

Circuit Protection - Refer to upper unit nameplate.

PREPARATION AND POSITIONING OF THE ROOF TOP UNIT

1. Consult Sections I through IV of the roof unit installation instructions for mounting requirements of the roof unit.
2. Prepare the roof unit for installation with the ceiling plenum.

In the small parts package of the ceiling plenum is a low temperature sensor. The low temperature sensor (See Figure 4) installs by inserting it straight in between the two lower evaporator tubes until contacting a tube, then raising the back of the probe and continuing at a 45° angle until the probe is **fully** inserted.

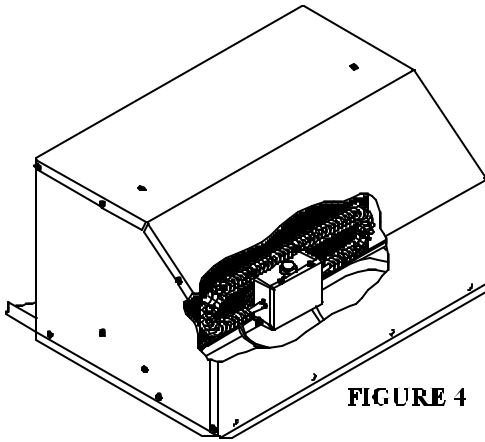

FIGURE 4

To gain access to the fins of the evaporator coil, reach up through the return air opening in the bottom of the roof top unit. Insure that the thermistor wire is routed to avoid contact with the heater element and the thermistor is located so as to be “shaded” by the heater control box (See Figure 4).

3. Install foam basepan pad at this time. See Figure 5. Pad is provided with adhesive on one side with release paper.

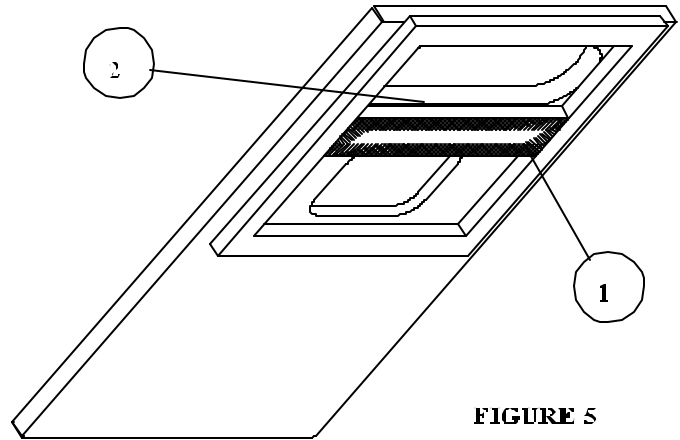

FIGURE 5

INSTALLATION OF HEATER ASSEMBLY

1. Position the heater assembly into the return air opening as shown in Figure 6. Insure that the set screw is retracted sufficiently to allow installation over the basepan extrusion (See Figure 6.)

The heater bracket **must be installed between the basepan and the plastic drain pan.**

2. Tighten set screw to secure the assembly so as to prevent movement.

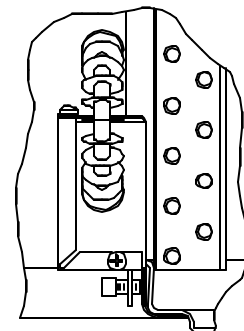

FIGURE 6

CEILING PLENUM PREPARATION AND MOUNTING

A. Preparation

1. Locate foam topped, three-sided telescoping divider plate (Reference Figure 7). Insert telescoping divider plate between the back of the ceiling plenum electrical box and the vertical insulated divider directly behind it. For adjustment purposes, it may be necessary to loosen the sheet metal screws in the telescoping divider.
2. Remove ceiling plenum electrical box. Retain box and two screws for reattachment. See Figure 7.

Familiarize yourself with the high voltage wiring box, strain relief and wiring. The 240V supply wiring must be routed through the strain relief in the high voltage wiring box and secured to wiring inside. Extend the three high voltage wiring box leads and prepare them for attachment to the supply wiring.

3. A low voltage terminal strip on the front of the box connects to the thermostat wires.

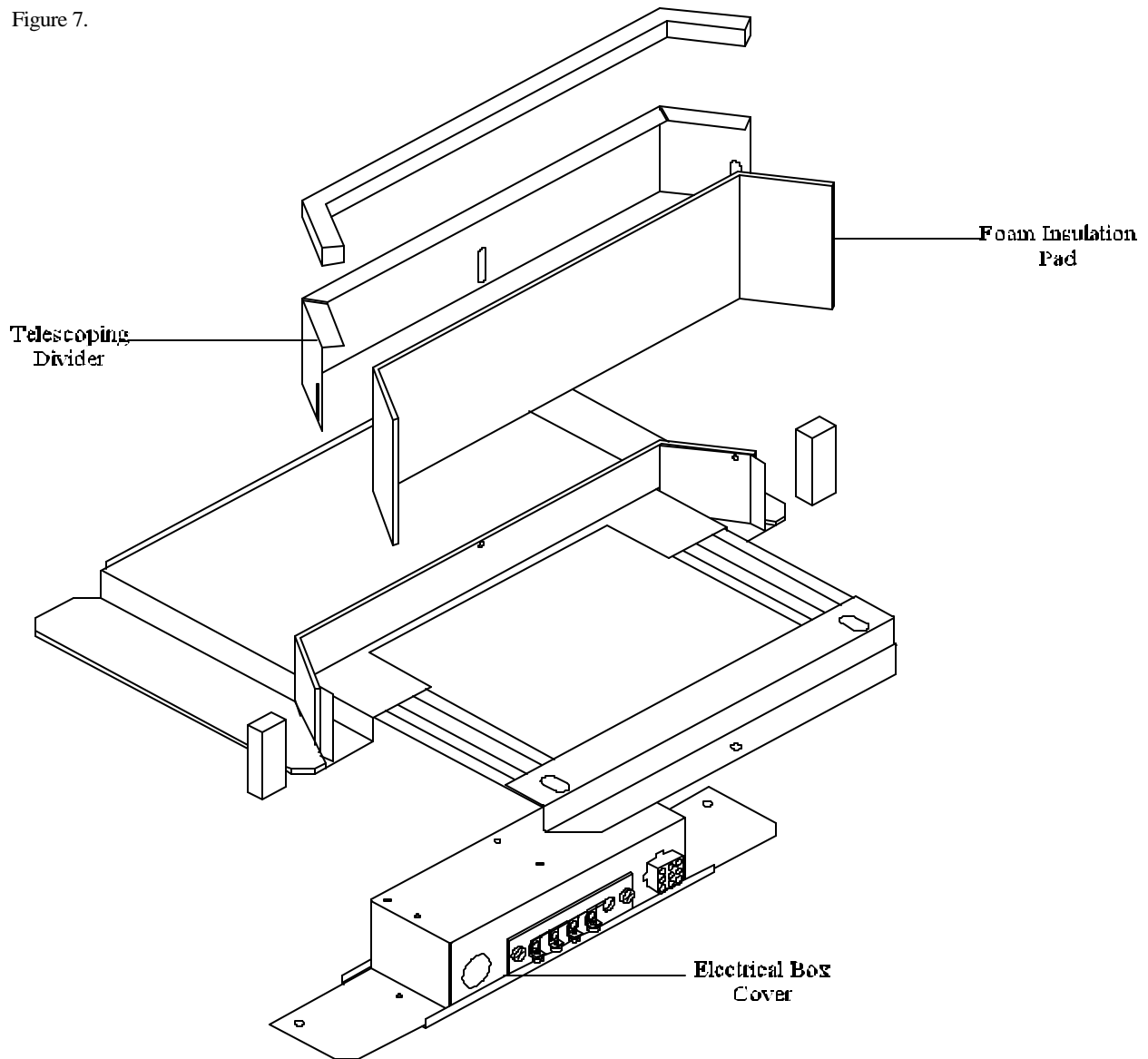

FIGURE 7

B. Mounting

1. After having prepared the roof top unit, place it over the roof opening.
2. Position ceiling plenum into the ceiling opening. For proper orientation of the ceiling plenum, reference Figure 6.

NOTE

When inserting the plenum into the roof opening, be careful not to pull the foam insulation away from the sides of the ceiling plenum. The insulation is required to create a positive air seal within the ceiling cavity.

3. Using the four bolts and washers provided, secure the ceiling plenum to the roof top unit. The four mounting bolts are to be applied up through the bottom of the ceiling plenum and into the bottom of the roof top unit.

NOTE

Mounting bolts should be tightened evenly. A rotating tightening procedure (similar to car tire rim mounting) is essential for proper gasket compression. The bolt tightening procedure is complete when the gasket under the roof top unit has been evenly compressed 1/4".

4. Locate the roof unit conduit assembly. Route the conduit through the return opening.

Raise the divider until it seals against the bottom of the roof top unit. Secure the telescoping divider in its new position by tightening the two screws.

Verify that the roof top unit 240V electrical conduit will mate (without pinching or straining any wiring), with the 240V plug and conduit from the ceiling plenum electrical box. Attach electrical box to ceiling plenum with the two supplied screws.

IMPORTANT

When connecting the 240V electrical conduit:

- 1) **Make any adjustments required to relieve pinched or stressed wiring.**
- 2) **Verify that the "ridged" side of both plugs are properly aligned. Verify that the connectors have snapped together on both sides. Do not use excessive force when joining the connectors.**
- 3) **Connect the heater assembly conduit into the receptacle at the end of the control box. Insure that the connector "snaplocks" into position.**

5. Measure how far the divider plate extends above the ceiling plenum electrical box. Using this measurement trim the adhesive backed foam insulation pad (provided with this package) to this measurement. Peel off the adhesive backing and apply the insulation pad to the raised divider plate. The insulation pad is longer than the roof opening (See Figure 6).

NOTE

Be sure to create a positive air seal both top to bottom and side to side within the roof opening.

6. Insert the freeze circuit thermistor probe into the roof top unit evaporator coil. Verify that the probe is located in the coil properly (See Figure 4).

CONNECT 240 VAC WIRING

1. WARNING - SHOCK HAZARD

To prevent the possibility of severe personal injury or equipment damage due to electrical shock, always be sure the electrical power is disconnected or off before beginning installation.

2. Complying with the "Danger" notice below, bring the 240 VAC supply wiring previously routed into the frame of the roof opening, through the strain relief atop the electrical box and into the high

voltage wiring area.

DANGER

WHEN USING NON-METALLIC SHEATH SUPPLY CABLES (ROMEX, ETC.), STRIP SHEATH BACK TO EXPOSE 4-6 INCHES OF THE SUPPLY LEADS. STRIP THE INDIVIDUAL WIRE LEAD ENDS FOR WIRE CONNECTION (ABOUT 3/4" BARE WIRE). REMOVE NYLON STRAIN RELIEF FROM ELECTRICAL BOX.

INSERT THE SUPPLY WIRES INTO THE STRAIN RELIEF. WIRE SHEATH MUST PROTRUDE PAST STRAIN RELIEF. MAKE SURE SHEATH CABLE IS CENTERED IN STRAIN RELIEF BEFORE SNAPPING IT BACK INTO BOX.

IF OTHER THAN NON-METALLIC CABLES ARE USED FOR SUPPLY CONDUCTORS, APPROPRIATE STRAIN RELIEF CONNECTORS OR CLAMPS SHOULD BE USED.

IN NO CASE SHOULD CLAMPING OR PINCHING ACTION BE APPLIED TO THE INDIVIDUAL SUPPLY LEADS (NEUTRAL AND “HOT” WIRES).

4. Gently fold all wiring into the electrical box while verifying that it is not either pinched or cut.
5. Complying with the warnings listed below, connect the 240 VAC supply wiring to its power source. Be sure all power remains off until beginning checkout procedure.

CONNECT THERMOSTAT WIRING

A. Ceiling Plenum Connections

1. Bring the thermostat wiring previously routed into the roof opening over to the low voltage terminal board extending from the front of the ceiling plenum electrical box.

These low voltage ceiling plenum designations complete the following circuits:

- B -12 VDC for all relay coils
- Y +12 VDC for compressor relay coil
- GH +12 VDC for hi fan relay coil
- GL +12 VDC for low fan relay coil
- W +12 VDC for heater relay coil

Recommended wall thermostat is RV Products part number 7330D3351 with sub-base part number 7330-3401. The sub-base allows the one thermostat to control cooling and either electric or gas heat as selected by the user.

Ceiling Plenum Low Voltage Wire Designations	Mate With	Wall Thermostat Control Wiring
B		Blue
Y		Yellow
GH		Green
GL		Gray
W		White

AFTER INSTALLATION, INSURE THAT NO WIRING COMES INTO CONTACT WITH THE HEATER ELEMENT AND THAT NO WIRING IS PINCHED.



RV Products
A Division of Airxcel, Inc.
P.O. Box 4020
Wichita, KS 67204