



OPERATION AND MAINTENANCE

INSTRUCTIONS

FOR

6571 SERIES

PACKAGE AIR CONDITIONERS

TABLE OF CONTENTS

I.	Specifications - A/C	2
II.	General Information	2
III.	Electromechanical Thermostat	2
IV.	Maintenance	4

I. SPECIFICATIONS

USE THERMOSTAT MODEL 7330-324 SUPPLIED WITH ACCESSORY KIT #6531A625		
240 VOLTS A/C	50 HZ	1 PHASE
COMPRESSOR MOTOR (THERMALLY PROTECTED)	RLA	4.3
	LRA	19.3
ELECTRIC HEATER	FLA	6.7
BLOWER/FAN MOTOR 1/4 H.P.	FLA	1.5
MINIMUM CIRCUIT AMPACITY	AMP	10
MAXIMUM OVERCURRENT PROTECTIVE DEVICE	AMP	10
R-22 CHARGE WEIGHT	OZ	14.75
UNIT 6571C662	WEIGHT	75 LBS.
	LENGTH	22 1/8
	DEPTH	18 1/8
	HEIGHT	19 3/4
ACCESSORY KIT 6531A625	WEIGHT	28 LBS.
	LENGTH	15 7/8
	DEPTH	16 9/32
	HEIGHT	10

II. GENERAL INFORMATION

This air conditioner contains a compressor refrigeration system. It provides the cooling capacity of a 7,000 BTUH air conditioner into a highly efficient and compact package.

A 1600 watt electric heater provides 5,460 BTUH of heating. This packaged air conditioner mounts on the roof of elevator cabs or like-sized indoor structures.

III. ELECTROMECHANICAL THERMOSTAT

This thermostat is designed to operate a 24 VAC controlled heating and air conditioning system. It can control one stage of heating and one stage of cooling. It is a manual changeover type thermostat between heating and cooling.

Manual changeover indicates that the operator must manually switch the thermostat from cooling to heating. The thermostat will not make this change automatically. This thermostat is provided as a component of the 6531A625 accessory package.

7330-324 HEAT-COOL THERMOSTAT

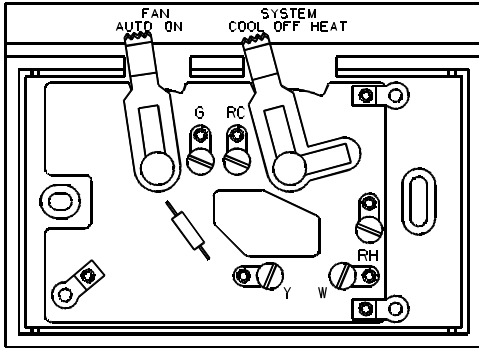

SUB-BASE

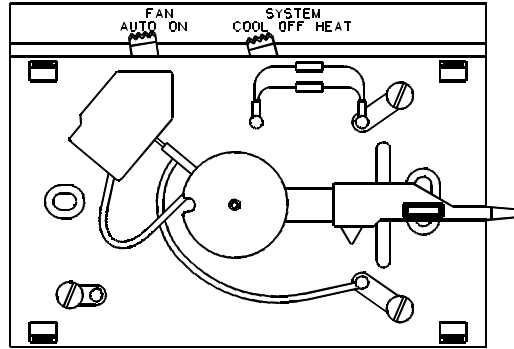

BI-METAL PLATE

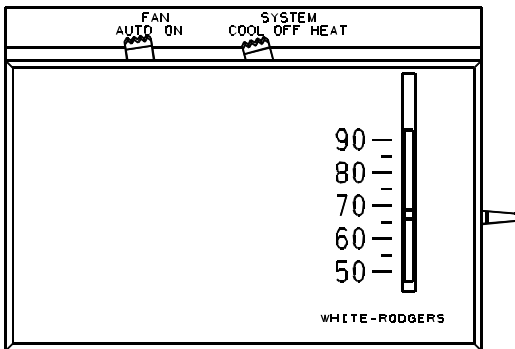

COMPLETE ASSEMBLY
BI-METAL PLATE SCREWED
TO SUB-BASE AND WITH
SNAP-ON COVER

ELECTROMECHANICAL THERMOSTAT OPERATION

The chart below details system functions.

<div style="display: inline-block; width: 15px; height: 15px; background-color: black; margin-right: 5px;"></div> SHOWS POSITION OF SWITCH					OPERATION
FAN		SYSTEM			
AUTO	ON	COOL	OFF	HEAT	
<input checked="" type="checkbox"/>	<input type="checkbox"/>	<input checked="" type="checkbox"/>	<input type="checkbox"/>	<input type="checkbox"/>	Compressor and blower cycle as required.
<input checked="" type="checkbox"/>	<input type="checkbox"/>	<input type="checkbox"/>	<input checked="" type="checkbox"/>	<input type="checkbox"/>	No function occurs.
<input checked="" type="checkbox"/>	<input type="checkbox"/>	<input type="checkbox"/>	<input type="checkbox"/>	<input checked="" type="checkbox"/>	Heater and blower cycle as required.
<input type="checkbox"/>	<input checked="" type="checkbox"/>	<input checked="" type="checkbox"/>	<input type="checkbox"/>	<input type="checkbox"/>	Blower runs continuously. Compressor cycles as required.
<input type="checkbox"/>	<input checked="" type="checkbox"/>	<input type="checkbox"/>	<input checked="" type="checkbox"/>	<input type="checkbox"/>	Blower runs continuously. <u>No</u> heating or cooling function occurs.
<input type="checkbox"/>	<input checked="" type="checkbox"/>	<input type="checkbox"/>	<input type="checkbox"/>	<input checked="" type="checkbox"/>	Blower runs continuously. Heater cycles as required.

IV. MAINTENANCE

One of the biggest advantages of owning an RV Products air conditioner is that required maintenance is minimal.

In fact, the only routine maintenance is the cleaning of the return air filter.

A washable type air filter is supplied with 6531A625 accessory kit. It is accessible by removing the end plate from the return air bonnet (connected to the 10" dia. flex duct).

If the filter is not cleaned at regular intervals (once per month is recommended), it may become partially clogged with lint and dirt. A clogged filter will produce a loss of air volume and may eventually cause equipment damage.

Do not operate the air conditioner without a return air filter. Operating the system without a filter allows the lint and dirt that is normally trapped by the filter to accumulate on the cooling coil of the air conditioner. This will lead to a loss of air volume, possible equipment damage and an expensive cleaning process.

Periodically (once or twice a season), inspect the condenser coil and brush off any accumulated residue with a soft bristled brush.

RV Products
A Division of Airxcel, Inc.
P.O. Box 4020
Wichita, KS 67204

