



# **INSTALLATION INSTRUCTIONS**

**FOR**

**7332-4551 HEATER ACCESSORY**

**RV Products  
A Division of Airxcel, Inc.  
P.O. Box 4020  
Wichita, KS 67204**

# TABLE OF CONTENTS

**Warnings** ..... 2

**Package Contents** ..... 2

**General Information** ..... 2

**Installation Of Heater Assembly** ..... 3

**Wiring Diagram** ..... 4

## WARNINGS

### IMPORTANT NOTICE

1. These instructions are for the use of qualified individuals specially trained and experienced in installation of this type equipment and related system components.
2. Installation and service personnel are required by some states to be licensed. **PERSONS NOT QUALIFIED SHALL NOT SERVICE THIS EQUIPMENT.**

### WARNING

3. Improper installation may damage equipment, can create a hazard and will void the warranty.
4. The use of components not tested in combination with these units will void the warranty, may make the equipment in violation of state codes, may create a hazard and may ruin the equipment.

### WARNING - SHOCK HAZARD

5. To prevent the possibility of severe personal injury or equipment damage due to electrical shock, always be sure the electrical power to the appliance is disconnected.
6. **CAREFULLY FOLLOW ALL INSTRUCTIONS AND WARNINGS IN THIS BOOKLET TO AVOID DAMAGE TO THE EQUIPMENT, PERSONAL INJURY OR FIRE.**

### NOTE

**The words “Shall” or “Must” indicate a requirement which is essential to satisfactory and safe product performance.**

**The words “Should” or “May” indicate a recommendation which is not essential and not required, but which may be useful or helpful.**

## PACKAGE CONTENTS

- |                    |                         |
|--------------------|-------------------------|
| 1) Heater Assembly | 1) Selector Switch Knob |
|--------------------|-------------------------|

## GENERAL INFORMATION

This heater accessory kit is intended to be installed with a 7330-763 or 7330-764 manual control ducted ceiling assembly to provide 5460 BTUH of electric heat. The ceiling assembly

comes with a heat/cool thermostat and a two pin heater wire receptacle to facilitate installation of this accessory.

## INSTALLATION OF HEATER ASSEMBLY

1. Remove the control and thermostat knobs, grilles and filters.
2. Position the heater assembly into the return air opening as shown in Figure 1. Insure that the set screw is retracted sufficiently to allow installation over the basepan extrusion (See Figure 2).  
  
The heater bracket **must be installed between the basepan and the plastic drain pan.**
3. Tighten set screw to secure the assembly so as to prevent movement.
4. Remove and discard the two pin safety plug from the ceiling assembly and plug in the heater umbilical. The plugs must “snap-lock” into position. **Insure that the umbilical does not contact the heater sheath.**
5. Replace the return air grille/filter and reinstall the temperature control knob. Use the selector switch knob found in this kit and discard the original “cool only” knob.

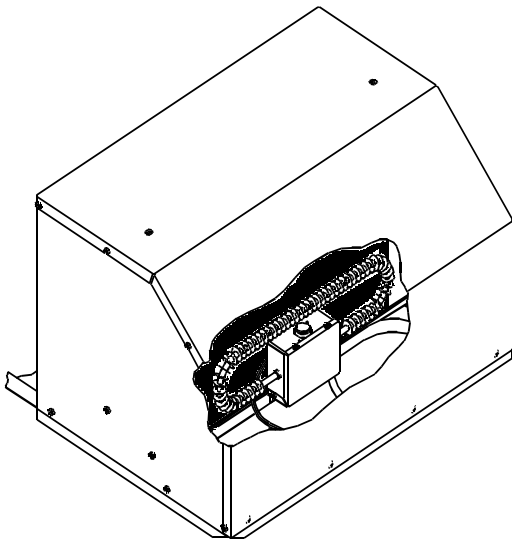

FIGURE 1

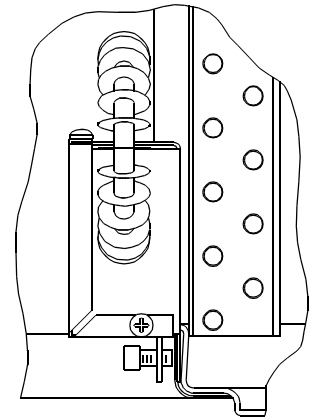

FIGURE 2

# WIRING DIAGRAM FOR 7330-76\* FLUSH MOUNT CEILING PLENUM

**RECREATION VEHICLE PRODUCTS, INC.**  
WICHITA, KS 67204

APPROVED FOR NON-METALLIC SHEATH  
SUPPLY CABLES SUPPLY WIRES 12 AWG.  
MIN. USE COPPER CONDUCTORS ONLY.

DANGER SHOCK HAZARD! DISCONNECT  
POWER SUPPLY BEFORE SERVICING ANY  
ELECTRICAL COMPONENT.

CHECK TERMINAL LOCATIONS FOR  
CORRECT CONNECTIONS AND SPACING  
BEFORE OPERATION.

AVIS! DEBRANCHEZ LES FILS ELECTRIQUES  
INTRETIEN ET DE TOUT COMPARTIMENT OR  
ORGANE ELECTRIQUES.

USE TIME DELAY FUSE MAX. AMP 20 OR  
CIRCUIT BREAKER MAX. AMP 20  
U.L. H.A.C.R. TYPE MAX. AMP 20

